

POMPE AD INGRANAGGI REVERSIBILI FISSAGGIO 4 FORI-ISO

CODICE FAMIGLIA
FAMILY CODE

105048

**4 HOLES-ISO REVERSIBLE
HYDRAULIC GEAR PUMPS**

DTH ISO

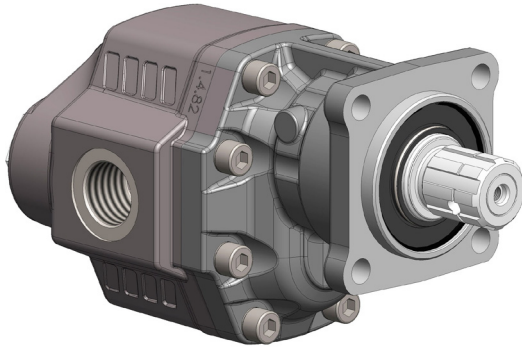

Fluido idraulico Fluid	Minerale o sintetico compatibile con guarnizioni: Mineral or synthetic compatible with the following seals: NBR, FKM, FPM, Nylon				
Viscosità cinematica consigliata Kinematic viscosity suggested	T media ambiente (°C) Average ambient temp. (°C)	< -10	-10 ÷ 10	10 ÷ 35	> 35
	VG (cSt = mm ² /s)	22	32	46	68
Viscosità cinematica ottimale di esercizio Optimale kinematic viscosity			VG = 10 cSt ÷ 100 cSt		
Viscosità cinematica max consentita all'avviamento Max kinematic viscosity suggested at the start-up			VG = 750 cSt		
Indice di viscosità consigliato Viscosity index suggested	VI > 100	Temperatura di esercizio Working temperature -15°C +100°C			
Grado di filtrazione Oil filtering			> 200 bar: 10 μm < 200 bar: 25 μm		
Pressione di aspirazione/Inlet pressure			-0,3 ÷ 2 bar		
Senso di rotazione/Pump rotation			Bidirezionale Bidirectional		

DTH-61/DTH-82

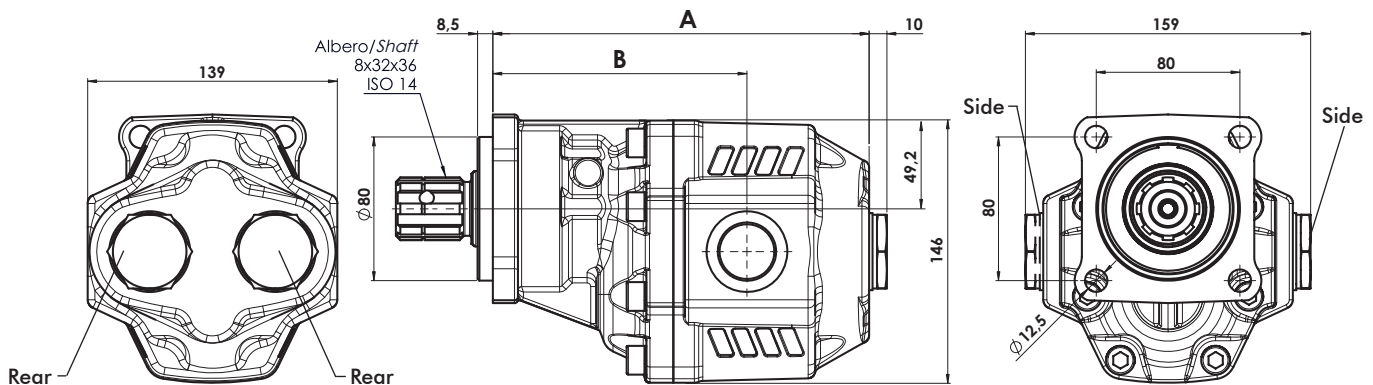

Tipo pompa Pump type	Codice ordinazione Order code	Laterali Side	Posteriori Rear	A	B	Peso Weight
DTH-61	10504810616	ISO 228	ISO 228	mm	mm	Kg
DTH-82	10504810821	G 1		196,5	136,5	15,3
				209,5	140,5	16,3

CARATTERISTICHE TECNICHE DI FUNZIONAMENTO TECHNICAL FEATURES

Tipo pompa Pump type	Cilindrata Displacement cm ³ /rev	Pressione Pressure			Velocità max. continua Max. continuous speed	Velocità max. intermittente Max. intermittent speed	Velocità min. Min. speed
		P1 bar	P2 bar	P3 bar			
DTH-61	60,06	205	225	230	1900 rpm	2500 rpm	300 rpm
DTH-82	81,08	205	225	230	1900 rpm	2500 rpm	

P1 = Pressione max. continua
P2 = Pressione max. intermittente
P3 = Pressione max. di punta

Max. continuous pressure (100%)
Max. Intermittent pressure (20 sec.max.)
Max. peak pressure (6 sec.max.)

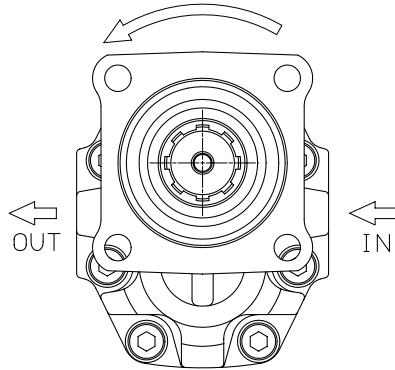
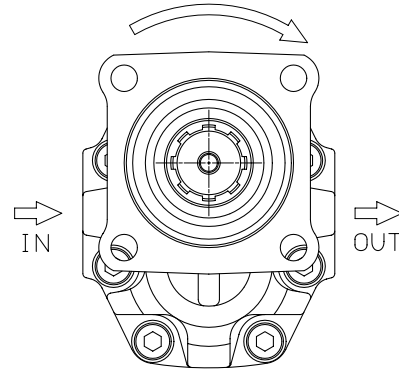
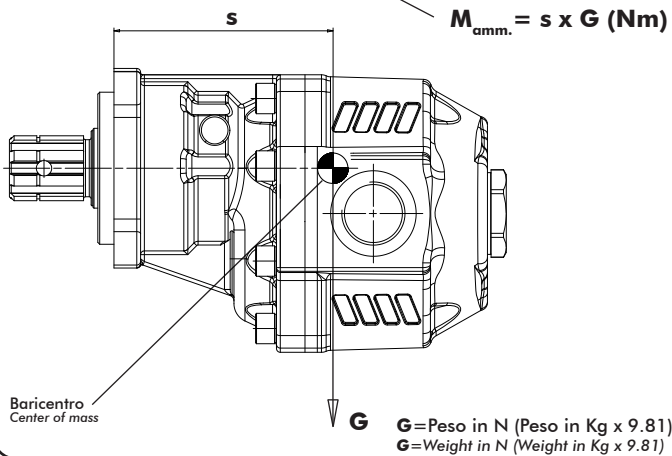
CARATTERISTICHE TECNICHE DI FUNZIONAMENTO - TECHNICAL FEATURES**Rotazione antioraria, pompa sinistra**
Anti-clockwise rotation, left pumpVista FRONTALE
FRONT**Rotazione oraria, pompa destra**
Clockwise rotation, right pumpVista FRONTALE
FRONT**MOMENTO PESO / MASS MOMENT****Tipo pompa - Pump type****S****DTH-61**

109

DTH-82

117