

**PRESA DI FORZA A
COMANDO PNEUMATICO
PNEUMATIC CLUTCH
POWER TAKE-OFF**

CODICE PTO **052-018-90137**
PTO CODE

**CAMBIO
GEARBOX**

EATON

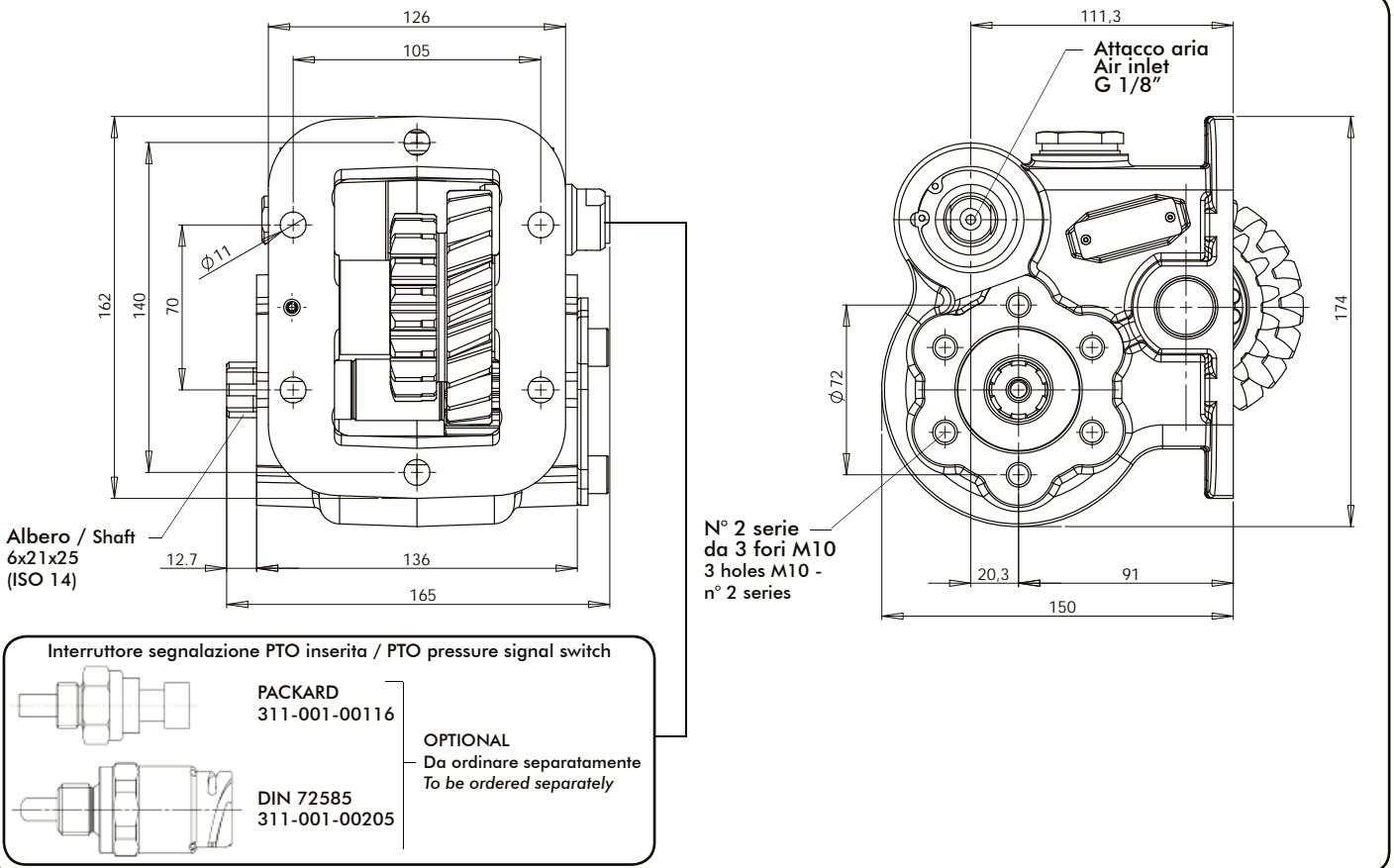
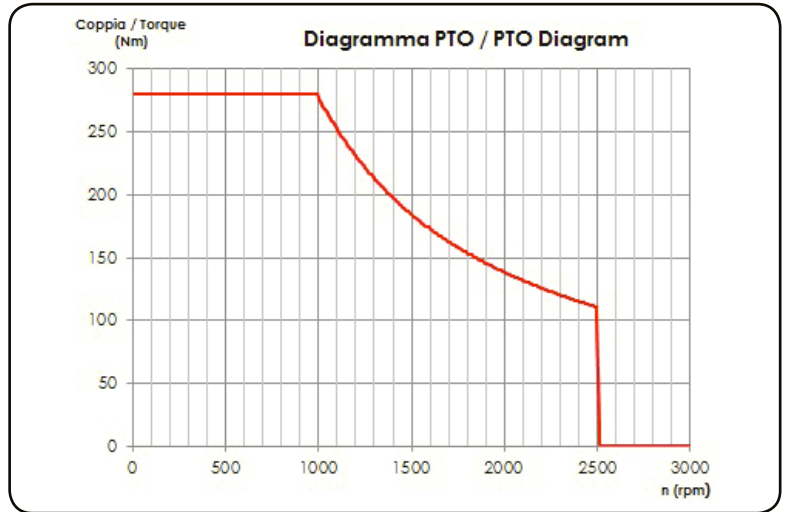

Tipo cambio Gearbox	Codice PTO PTO code	Versione Version	Giri pto a 1000 giri motore Pto ratio@1000 eng.rpm	Coppia massima Max torque	Lato montaggio Mounting side	Uscita Output	Rotazione Rotation	Kit di montaggio Mounting kit	Peso Weight
FS 5406N 6406N	052-018-90137	13	1150 rpm	280 Nm	Sx. Left	Post. basso Rear down	Orar Cw	154-003-05024	10,8 Kg

Data: Lunedì 28 maggio 2018

Codice foglio:997-252-90137 Rev:AD