

"HIGH POWER"

HIGH PERFORMANCE PTO

CODICE PTO
PTO CODE

01004515179

CAMBIO
GEARBOX

ZF ECOSPLIT

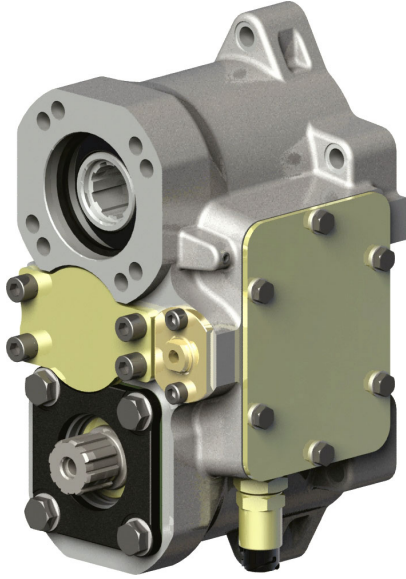

CONDIZIONI DI FUNZIONAMENTO / WORKING CONDITIONS

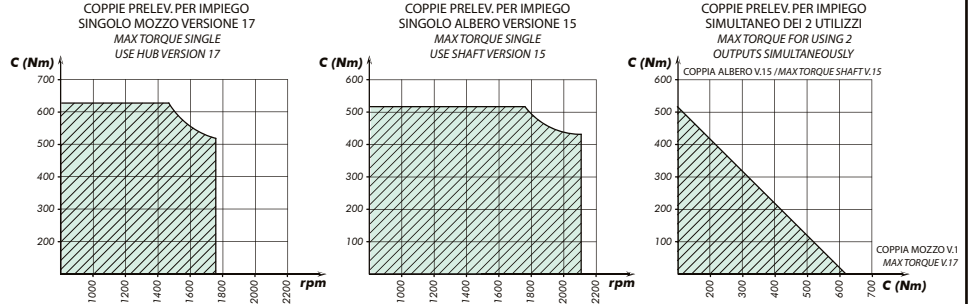

Il grafico qui riportato, che indica il prelievo di coppia in funzione del numero di giri, riguarda solamente la PTO. È necessario verificare il limite di prelievo di potenza dal cambio prima di effettuare l'applicazione.
The graph indicating the allowed torque according to the RPM refers to the PTO only. It is necessary to check the torque limit of the gearbox before fitting the PTO.

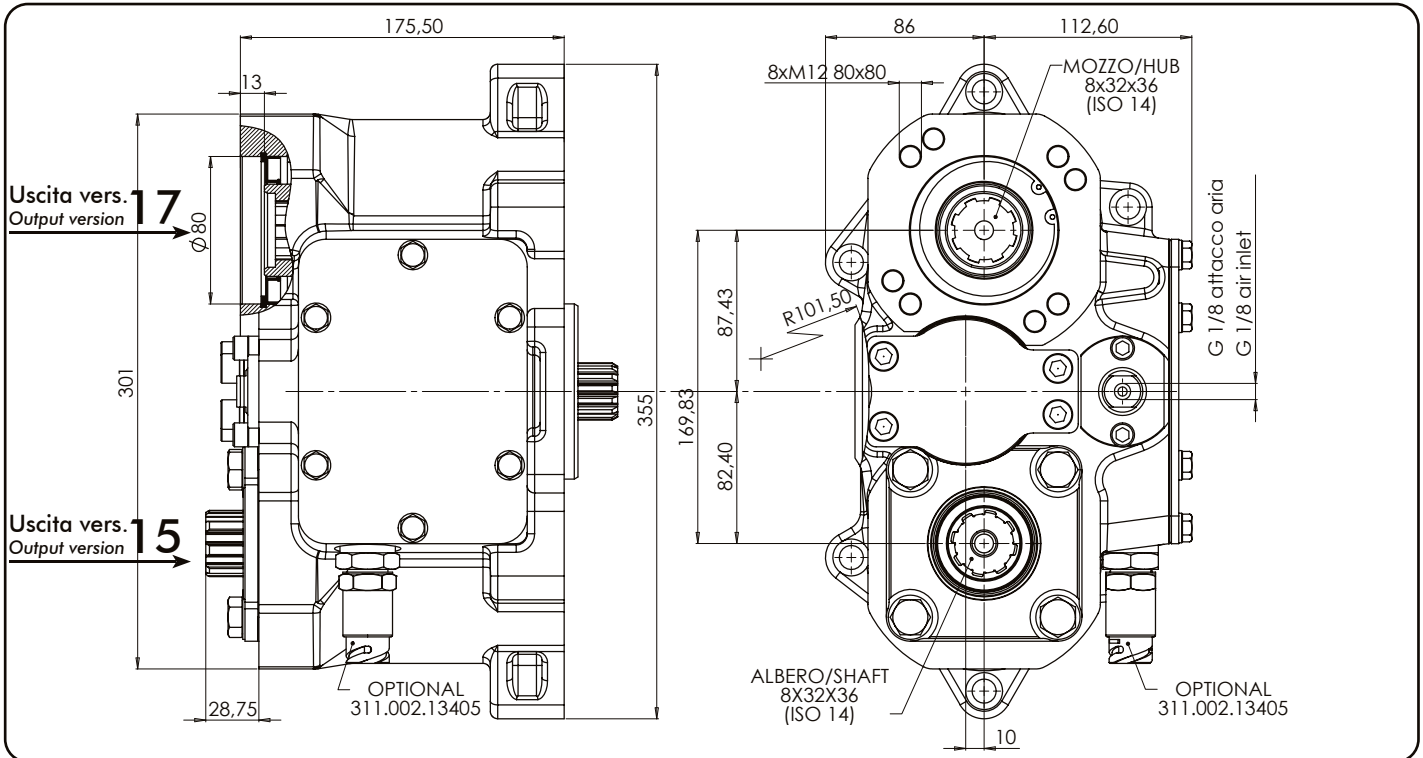

Codice PTO PTO code	Rapporto Ratio	Versione Version	Giri pto a 1000 giri motore Pto ratio@1000 eng.rpm	Coppia massima Max torque	Rotazione Rotation	Peso Weight
			rpm	Nm		Kg
01004515179	1,93	15	IN FUNZIONE DEI CAMBI ACCORDING TO THE GEARBOXES	510	Antioraria Ccw	25
	1,61	17		620		

pag.10

COMPANY WITH
QUALITY SYSTEM
CERTIFIED BY DNV GL
= ISO 9001:2015 =

O.M.F.B. S.p.A. Hydraulic Components
We reserve the right to make any changes without notice.
Edition 2005.09 No reproduction, however partial, is permitted.
Via Cave, 7/9 25050 Provaglio d'Iseo (Brescia) Italy Tel.: +39.030.9830611
Fax: +39.030.9839207-208 Internet:www.omfb.it e-mail:contatti@omfb.it



18/03/2021

9974000040

07/02/2011

99721045215 Rev: AB